

INSTALLATION INSTRUCTIONS

DESCRIPTION: GYTR® High Perf. Camshafts
 PART # B2W-E21F0-V0
 MODEL: '20~ YZ450F



⚠ WARNING

Please read and understand these instructions completely before installation to avoid possible injury, or damage to the accessory or vehicle.

IMPORTANT: YZ models are for closed-course competition only regardless of modification. YZ models do not meet federal or state emission standards for recreational off-road use.

NOTICE:

Installation of this kit requires specialized tools, and training, as well as the Owner's Service Manual for the model. This installation should be performed by an authorized Yamaha dealer or a qualified mechanic.

WARRANTY INFORMATION:

In the United States, see your Yamaha dealer for a copy of the limited warranty statement.

DEALER OR INSTALLER:

These instructions contain important information for future reference and *must* be given to the customer.

For best performance outside the U.S. market, contact your local distributor for a list of accessory kits, power tuner settings, and fuel requirements.

For best performance, install the High Performance Camshafts Kit in conjunction with these kits:

- GYTR Ported Cylinder Head p/n# **B2W-E11B0-V0**
- GYTR High Flow Air Filter p/n# **BR9-E41C0-V0**
- GYTR Piston p/n# **B2W-E16A0-V0**
- GYTR by FMF Muffler p/n# **BR9-E47A0-V0**
- GYTR by FMF Header p/n# **B2W-E46A0-XX**

PARTS LIST:

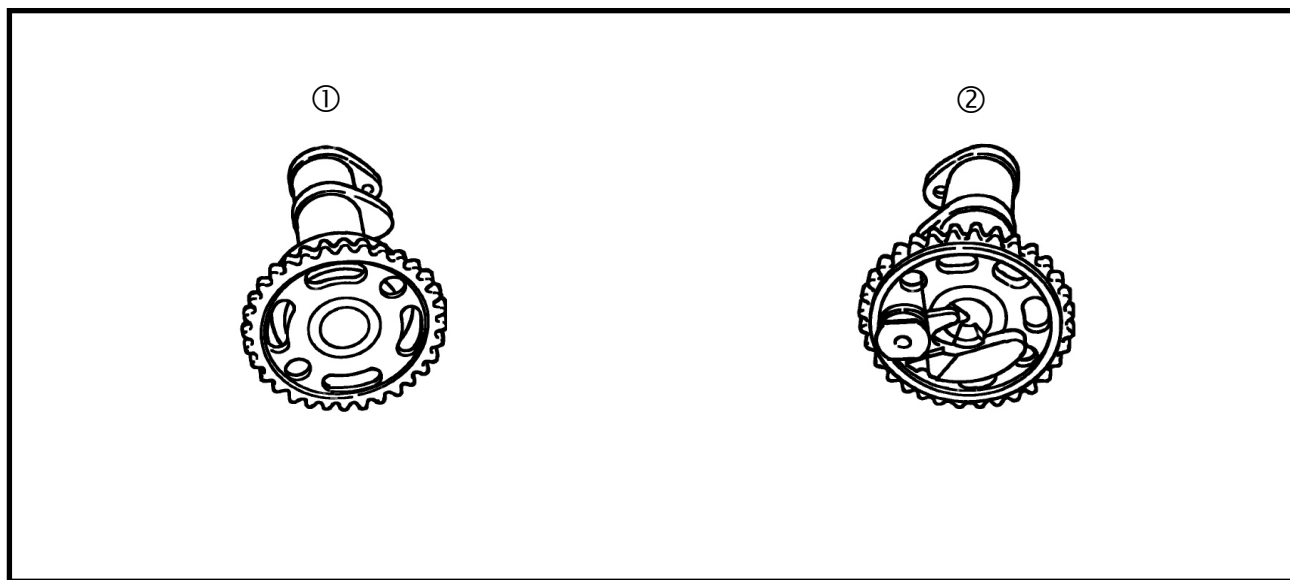

No.	Part Number	Description	Qty
--	B2W-E21F0-V0	High Performance Camshafts	--
①	*	Intake Camshaft	1
②	*	Exhaust Camshaft	1

* Part supplied with kit only and not available separately.

Fig. 1

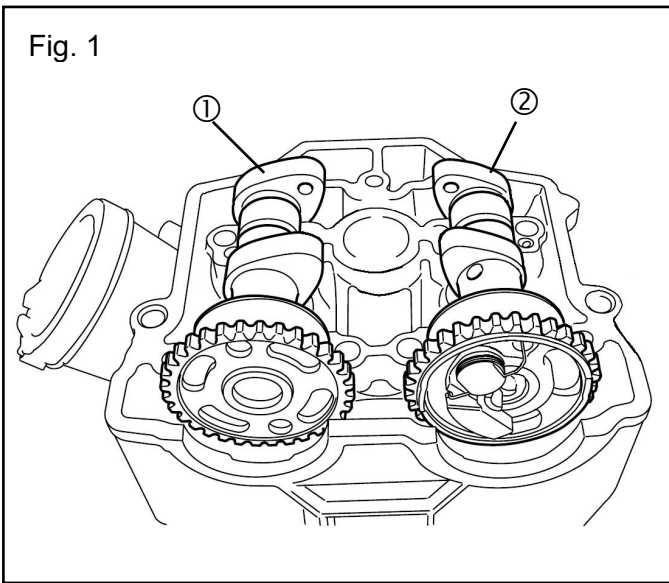

PREPARATION

- Stand the motorcycle on a secure and level surface.
- Clean all mounting surfaces before beginning installation.

INSTALLATION:

Please refer to the Yamaha Service Manual for detailed disassembly and assembly procedures.

NOTICE:

The durability and performance gains from the GYTR Camshaft Kit are dependent on many factors including: Correct fuel calibration, engine tuning, performance modifications, riding style, and head porting.

Yamaha only recommends 100+ octane fuel. Using a fuel with a lower octane rating can cause detonation, which may lead to catastrophic engine failure.

Yamaha strongly recommends Yamalube® 15W-30 Full Synthetic Racing Oil (P/N LUB-15W30-FS-12) be used with this engine after this kit is installed.

MAINTENANCE:

Periodically check all hardware and re-torque as needed.

- Change oil and oil filter every 4 hours of engine time.
- Change piston, piston pin, and oil rings as a set, every 12.5 hours of engine time.
- Inspect valves, valve springs, valve lifters, camshafts, cylinder head, and cylinder every 12.5 hours of engine time.
- Replace components as needed.

CUSTOMER SERVICE:

For further information see your Yamaha dealer.

ESTIMATED TIME TO INSTALL: 1.3 HRS